

M5

Mag Pro

with SQR Fit System + APP

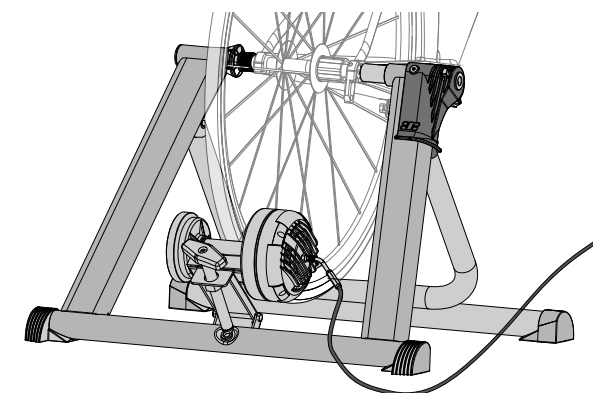

4) USING YOUR TRAINER

GETTING THE BEST FROM YOUR TRAINER:

Do not ride your trainer with less than 1.5 complete turns (three half turns) of the roller adjustment knob after the roller first makes contact with the tyre. It is important that the tension between the tyre and the roller is set correctly every session for two reasons. (1) It ensures that the tyre will not slip on the roller which could cause permanent damage to the trainer and your tyre. (2) It ensures the resistance of your trainer is consistent for every training session allowing you to track performance.

The trainer base power curves used in the JetBlack app are measured on a bike using 700x23c slick road tyres at 110psi with exactly 1.5 complete turns (three half turns) of the roller adjustment knob after the roller first makes contact with the tyre. If your setup is different you will have a slightly different resistance, but as long as you keep the setup identical between each training sessions you will be able to monitor your performance. To make your indoor workout as quiet as possible, set the trainer on a JetBlack Trainer Mat and use a rear tyre with a smooth tread pattern. Once attached, the bicycle slopes downward slightly. To level, use the optional JetBlack Riser Block under the front tyre.

CONSISTENT REPEATABLE TRAINING SESSIONS:

1. Increasing the tension of the roller from our recommended 1.5 turns to 2 full turns will increase the resistance approximately 10-15%. So if you are using the trainer for tracking your power performance, you should resist adjusting the roller up to 2 full turns.
2. For every 20 psi your tyre deflates you will lose approximately 5% resistance. You must check your tyre pressure before every ride making sure it is inflated to whichever comes first the tyre manufacturer's maximum recommended pressure or 110psi if your tyres will allow.

Changing Trainer Resistance

This trainer has five levels of resistance to help keep variety in your workout program. To change the level, pull the handle bar mounted resistance knob inward or push it outward to obtain the desired level. Level one offers the least resistance while level five offers the most. Changing gears on your bike will also have an effect on your exertion levels.

IMPORTANT

Ensure the cable and housing between the resistance unit and the handle bar follows a continuous, smooth curve. Any kinks or bends must be removed. Do not coil or bunch the cable and housing whilst using the trainer. This will cause false cable adjustments and reduce the potential resistance of your trainer.

TRAINER SPARE PARTS

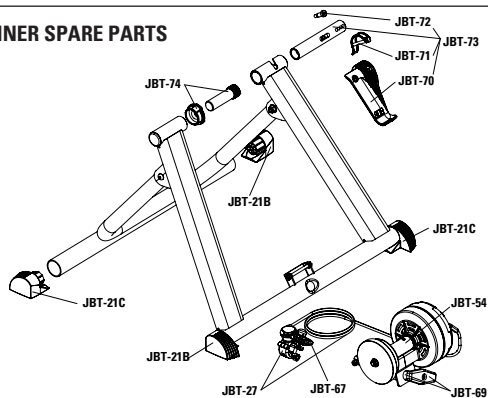

M5-PRO - TRAINER PARTS	
ITEM CODE	DESCRIPTION
JBT-70	JB SQR Lever - Black Nylon
JBT-71	JB SQR Linch Pin - Shaft Locking Pin With Spring Retainer
JBT-72	JB SQR Shoulder head bolt - Spiral Slot Bolt
JBT-73	JB SQR Lever Assembly With Barrel nut, Shoulder Head Bolt, Linch Pin & SQR lever
JBT-74	JB Threaded Adjustment Bolt Assembly With Locking Ring - Non Drive Side
JBT-21B	JB Foot For Trainer Base - Finned Design (LH)
JBT-21C	JB Foot For Trainer Base - Finned Design (RH)
JBT-22	JB Skewer For Trainer (not Pictured)
JBT-27	JB Remote Lever For MagPro With Cable
JBT-54	JB Resistance unit assembly (M1 Pro & M5 Pro)
JBT-67	M1 Pro Thumb Shift Levers
JBT-69	JB Resistance unit adjustment Bolt w' Lock nut and knob (Fluid/Mag)

5) BIKE REMOVAL

Undo the roller adjustment knob on by turning it anticlockwise 1.5 turns to back the roller away from the tyre. Hold your bike with one hand and with the other hand undo the drive side adjustment knob, turning it towards your bicycle frame. Now unscrew the outer adjustment knob until the axle support cups are unscrewed away from the bicycle. Now you may carefully remove the bike forwards or upwards, until it clears the trainer frame.

6) CARING FOR YOUR TRAINER

When used according to the manufacturer's instructions and cared for with common sense, your JetBlack trainer will provide a lifetime of training.

Wipe any sweat off after a workout.

Keep the machine away from any corrosive substances, such as salt or other potentially hazardous substances.

If the roller darkens or shows black tyre build up you may clean it off with a cloth. This tyre build up can be cleaned with a rag by friction rubbing the roller with a side to side motion. The rubbing motion with a clean rag will lift the tyre build up off the roller. Do not use alcohol or any cleaning solvents on the hydrogel roller. A clean cloth and friction is all that is required.

7) STORAGE

Caution! The trainer will become hot during use. Keep children and pets away and allow trainer 15 minutes to cool down before transporting or storing your trainer.

To store or transport your trainer:

Rotate the SQR lever down to the closed position

Grasp the trainer frame by the adjustment bolts/axle support cups and then lift so that you may fold the legs together.

Be careful when folding the legs to avoid pinching your fingers.

Store the trainer indoors, out of the rain and away from temperature extremes.

Keep the trainer away from any corrosive substances, such as salt or other potentially hazardous substances.

8) WARRANTY

JetBlack offers the original owner a lifetime warranty against manufacturing defects manufacturing defects in materials and workmanship. Units which use batteries or computer display unit come with a one year warranty on these products. This warranty is not applicable to damage caused by misuse, abuse, neglect, accident or unauthorized modification. If the unit is disassembled by the consumer, this warranty is void. It is the responsibility of the purchaser to retain receipts for proof of purchase in the event that warranty is required. Returning goods to JetBlack or the place of purchase is done at the owner's expense.

If you experience problems with your trainer, please email us at info@jetblackcycling.com

FREE JETBLACK TRAINING APP

New and exclusive to JetBlack!

Free app for iOS or Android with Multiple coaching sessions crafted by Olympic cycle coach Murray Healey.

- Upload your workout to Training Peaks and Strava!
- Test and monitor yourself with an in built Fitness/Zone test and Training Zone calculator
- View: Gear Recommendations, Goal Cadence, Session Time, Session Profiles. Optional accessories allow upgrades to include, Speed, Cadence, Heart Rate, Power (watts) and Calories Burnt



**DOWNLOAD YOUR
FREE JETBLACK APP**
www.jetblackcycling.com/app/rego_180



Use the above unique web address to register your details and receive an email with links for downloading the app on your preferred device.

1) WARNING

- Read and follow all instructions concerning trainer setup and installation of your bicycle into the trainer. Failure to securely attach the bicycle to the trainer could result in serious injury to the rider or bystanders.
- Remove all oils and moisture from the roller and the tyre before use.
- Keep both hands on handlebar at all times.
- Do not over-tighten the adjustment knobs. Over tightening may cause damage to the trainer or your bicycle frame. The clamp handles should be firm and secure. Do NOT force!
- Regularly check your trainer, particularly the mounting system, for damage. If you think your trainer may be damaged, do not use it and contact your supplier.
- Always take care when training to prevent children or pets moving close to the trainer.
- Do not use hard, specialty compound trainer tyres on the hydrogel roller. We have specially engineered the orange roller to reduce tyre wear and noise, eliminating the need for trainer tyres. Tyre wear with correct setup will be similar to that of riding on the road. Using a hard compound trainer specific tyre will cause slipping on the roller, which could cause permanent damage to the orange hydrogel roller. Use of hard compound trainer specific tyres is not covered by warranty.

2) CAUTION

- This trainer is intended for single-rider bicycles only.
- Read and follow all instructions.
- Before beginning each workout, be sure the bicycle is securely attached to the trainer.
- Ensure you always use the trainer on a flat surface.
- Do not put fingers, feet or dangling objects near any moving parts.
- Do not attempt to dismount until all moving parts have come to a standstill.
- Do not attempt to modify your JetBlack trainer.
- Do not attempt to stop the resistance unit or flywheel manually.
- Resistance unit can become hot enough to cause burns. Do not touch resistance unit during use and for some period after use, until it has had sufficient time to cool.
- Keep children and pets away from the trainer during use.
- Before you start any exercise program you should consult a physician. Should you become ill, feel dizzy, light-headed or nauseous while riding the trainer, stop riding immediately and seek medical attention.
- The roller adjustment knob must be tightened correctly to prevent damage to the trainer.

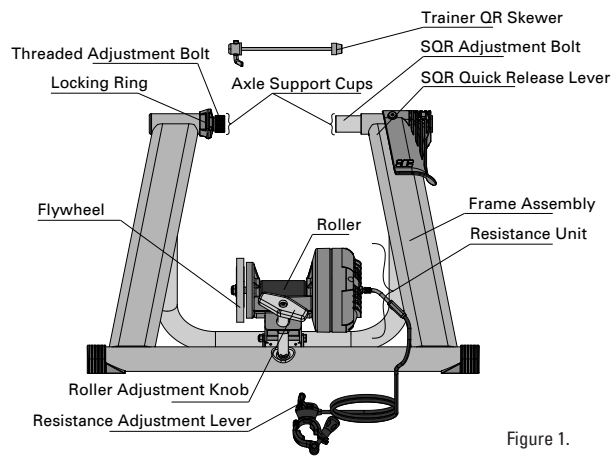

Figure 1.

3) BICYCLE MOUNTING

INITIAL SETUP

This setup must be followed every time a bicycle with a different axle length is used.

BICYCLE SETUP

1. Your bicycle must be in good mechanical condition, if you are unsure please see your local bicycle service centre for assessment.
2. Your bicycle wheel must be in good condition, true and free from any issues. The wheel's rim must have less than 2mm side to side movement and less than 1mm vertical movement per revolution. If your wheel is outside of this, please visit your local bicycle service centre to have it trued. Untrue wheels may cause vibration during use and could cause permanent damage to the trainer or trainer roller.
3. To measure fitness improvement it is important to use consistent tyre pressures for each workout.

For road bike tyres we recommend 110psi.

For mountain bike tyres please see that manufacturer's guidelines written on the tyre sidewall.

The trainer base power curves used in the JetBlack app are measured on a bike using 700x23c slick road tyres at 110psi with exactly 1.5 complete turns (three half turns) of the roller adjustment knob after the roller first makes contact with the tyre. Lower pressures can still be measured as long as they are used consistently.

4. Bicycle axle setup: Bicycle axles come in a range of sizes. You must select the correct setting on the SQR (Set Clip Quick Release) before attempting to mount your bicycle

Standard Nut and Bolt

- Ensure the nuts on your axle are tightened securely
- Check that the nut and axle nests into the axle support cups by more than 5mm (3/16 inch)

Quick Release Skewer

- JetBlack strongly suggests you use the supplied quick release skewer (for those bicycles that use QR systems)
- Replace the bicycle's rear wheel quick release (QR) skewer with the one provided. See your bicycle owner's manual for instructions on how to properly adjust the QR skewer.
- The skewer lever must be on the non-drive side of your bicycle (the left hand side).
- Your skewer must be tight and your wheel must be aligned properly in the bicycle.

Thru Axle

- Bicycles that use a thru axle system in most cases do not nest the minimum of 5mm (3/16 inch) into the axle support cups. If your thru axle does not nest more than 5mm (3/16 inch), you should acquire a trainer specific trainer thru axle that is suitable for your bicycle. These are sold separately.
- Install your trainer specific thru axle making sure to follow the manufacturer's instructions.

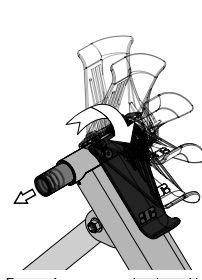

Figure 2.

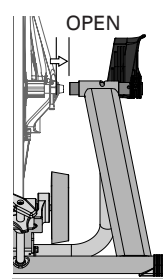

Figure 3.

SQR™ SETUP

SQR™ (Set-clip Quick Release) Fit System Setup:

The SQR™ (Set-clip Quick Release) has four available positions so that the trainer will suit most 26", 27.5", 29" 700c and some 24" bicycles. (24" bicycles and other bicycles will need to be fitted to the trainer on a case by case basis). See figure 4.

Your trainer comes supplied set in Position Two, See figure 4. This is the most common road bike width. To use a bike with another width, you simply select the appropriate SQR™ hole position and adjust the threaded bolt so that the lever is firm to close. Simply adjust the SQR™ system to match your bike and you're ready to ride. This is a once only required setup that does not need any further adjustment. It will be in the exact position every single ride. You will only need to reset if you are changing to a bike with a different sized axle.

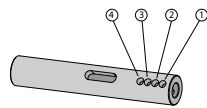

Figure 4.

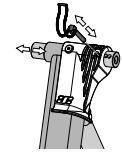

Figure 5.

Bike Style	4	3	2	1	Bicycle Axle Width
Track Bikes			•	•	Less Than 130mm
Road		•	•		Quick Release 130mm
MTB & Road-Disc		•	•		Quick Release 135mm
MTB		•	•		Thru Axle 12x142mm
Other		•			Greater than 142mm

Table 1.

IMPORTANT:

Ensure that your tyre is centred on the orange roller to within 10mm (3/8 inch) from the centre of the orange roller. Your tyre must have a minimum 5mm (3/16 inch) clearance from the metal (silver coloured) roller frame. See figure 6.

*Table 1 is a guide for attaining lever pin positions (1-4) for common bicycles and can be used as a starting point for other bicycle axle configurations. Some bikes may require moving the pin one hole either side to centre the tyre on the orange roller.

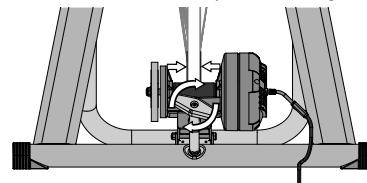

Figure 6.

1. From table 1, select the position number that best suits your bicycle.
2. Remove the pin from the lever and adjustment bolt and slide the adjustment bolt until the correct hole is aligned and then reinsert the shaft locking pin. See Figure 5

3. The Shaft Locking Pin must be inserted all the way so that its curved spring clips around to the closed position securing it to the trainer.
4. Now rotate the SQR™ plastic lever so that it is open (vertical position pointing up).
5. On the left hand side, adjust the silver threaded bolt and black plastic lock nut so that they are all the way in, with no thread showing. This will give you plenty of room as you move the bike into position. See Figure 3.
6. Check your tyre pressure is inflated to whichever comes first; the tyre manufacturer's maximum recommended pressure or 110psi if your tyres will allow.
7. Take your bike and gently lower your bike into the trainer frame. Align the bike and rear wheel to the left side of the trainer so that the bicycle axle is firmly resting inside the threaded adjustment bolt.

Note: If the roller is touching the tyre and not letting the axle nest into the axle support cup you may need to lower the resistance unit by winding the roller adjustment knob anti clockwise.

8. On the SQR™ lever side, now rotate the black plastic lever down to a horizontal position. See figure 8.
9. Check that your tyre is centred on the orange roller to within 10mm (3/8 inch) from the centre of the orange roller. Your tyre must have a minimum 5mm (3/16 inch) clearance from the metal (silver coloured) roller frame. See figure 6.
10. The lever should be easily rotated to the horizontal with little force and become firm to close after being pushed beyond horizontal (level with the ground), See figure 8.
11. If the lever requires effort to rotate to horizontal wind the adjustment bolt anti-clockwise until the lever sits horizontal (level with the ground)
12. If the lever requires no effort to rotate down below horizontal turn the adjustment bolt clockwise until the lever sits horizontal (level with the ground)
13. Now test the lever by applying a downward force and closing the lever all the way to the closed position. See figure 3. It should be firm to close, but still easy enough to close and open.
14. Check your setup matches figure 9. and that your lever is horizontal (level with the ground). If not, adjust as necessary until it does.
15. When you have completed step 13 make sure the black locking ring is rotated clockwise until it is firmly against the trainer frame. This will lock the threaded bolt in place, preventing it from tightening or loosening during use.
16. Check the bicycle is secure in the trainer frame. The bicycle must not move separately from the trainer. Test this by holding the bicycle saddle and moving it from side to side and up and down. If the bicycle moves please return to initial setup.
17. Finally check that the roller is tightened to exactly 1.5 turns (three half turns) after the tyre first makes contact with the roller.

ROTATE THREADED ADJUSTMENT BOLT UNTIL LEVER IS FIRM TO CLOSE FROM A HORIZONTAL POSITION. TEST WHEEL TO MAKE SURE BIKE IS SECURE

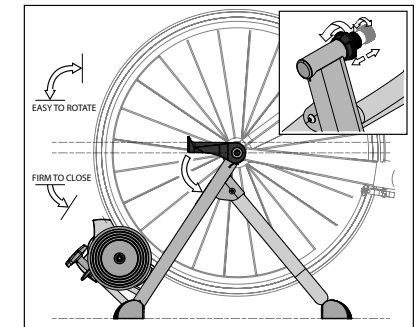

Figure 7.

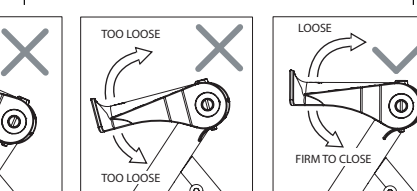

Figure 8.

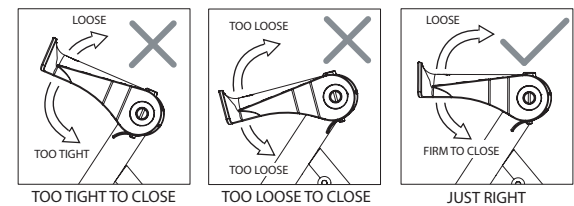

Figure 9.